

# MULTIFORM

ENCRUSTING MACHINE

# MIMAC





# MULTIFORM

## ENCRUSTING MACHINE

MULTIFORM è la nuova proposta di MIMAC ITALIA S.r.l. per la realizzazione di prodotti estrusi dolci e salati, con o senza farcitura, in grado di soddisfare i più esigenti laboratori di pasticceria e di gastronomia.

MULTIFORM è il risultato di un progetto all'avanguardia, finalizzato all'utilizzo della macchina per la produzione di biscotti con ripieno di creme o marmellate, gnocchi ripieni, arancini, crocchette, polpettine di carne, pesce o verdure, con o senza ripieno "Maamoul", "Kibbeh", "Coxinha", ecc.

MULTIFORM is the latest machine by MIMAC ITALIA S.r.l. for making sweet and savoury extruded products, with or without filling, which can satisfy the most demanding producers of pastry and gastronomy products.

MULTIFORM is the result of a state-of-the-art project aimed at using the machine to make biscuits with cream or jam filling, filled gnocchi, "Arancini" (stuffed rice balls), croquettes, meat, fish or vegetable balls, with or without filling, "Maamoul", "Kibbeh", "Coxinha", etc.

MULTIFORM est la nouvelle proposition de MIMAC ITALIA S.r.l. pour la réalisation de produits extrudés sucrés et salés, avec ou sans farce, en mesure de satisfaire les laboratoires des pâtisseries et des traiteurs les plus exigeants.

MULTIFORM est le résultat d'un projet à l'avant-garde, ayant pour but l'utilisation de la machine pour la production de biscuits fourrés à la crème ou à la confiture, gnocchis farcis, "Arancini" (boulettes de riz farcies), boulettes de pommes de terre frites, petites paupiettes de viande, poisson ou légumes, "Maamouls", "Kebbeh", "Coxinhas", avec ou sans farce, etc.

MULTIFORM es la nueva propuesta de MIMAC ITALIA S.r.l. para la realización de productos extrudidos dulces y salados, con o sin relleno, que puedan satisfacer a los laboratorios más exigentes de pastelería y de gastronomía.

MULTIFORM es el resultado de un proyecto de vanguardia, finalizado al uso de la máquina para la producción de galletas con relleno de cremas o mermeladas, ñoquies rellenos, "Arancini" (pasteles de arroz), croquetas, albóndigas de carne, pescados o verduras, con o sin relleno, "Maamoul", "Kibbeh", "Coxinha", etc.



[www.mimac.com](http://www.mimac.com)



MULTIFORM



OPZIONE  
OPTION  
OPTION  
OPCIÓN

Trasportatore prolungato  
Extended conveyor  
Convoyeur prolongé  
Cinta transportadora alargada



MULTIFORM può essere messa in linea e completata da un dispositivo di decorazione con stampi di vario formato e da un gruppo di scarico automatico dei prodotti, a tappeto retrattile, adatto per teglie di dimensioni 400x600 o 450x650 mm.

MULTIFORM can be inserted into an already-existing line and it is supplied with a decorating device with moulds of various sizes and an automatic product discharging with retractile belt system, suitable for trays of 400x600 or 450x650 mm.

MULTIFORM **LINE**



MULTIFORM peut être mise en ligne et complétée par un dispositif de décoration avec moules de différents formats, et par un groupe de déchargement automatique des produits, à tapis rétractile, adapté pour des plaques de cuisson de dimensions 400x600 ou 450x650 mm.

MULTIFORM puede ser puesta en línea y completada con un dispositivo de decoración con moldes de vario formato y con un grupo de descarga automática de los productos, con cinta retráctil, apto para bandejas de dimensiones 400x600 o 450x650 mm.

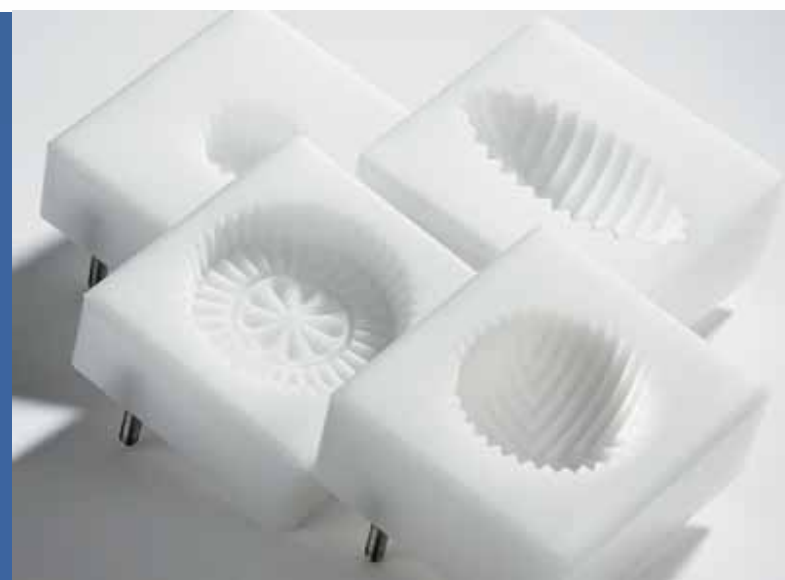



Tutte le parti a contatto alimentare sono state studiate per un rapido smontaggio e una facile pulizia.

All the parts that come into contact with food are purposely designed to be dismantled quickly and to be easy to clean.

Toutes les parties en contact alimentaire ont été étudiées pour être démontées rapidement et nettoyées facilement.

Todas las partes en contacto alimentario se han estudiado para un desmontaje rápido y una limpieza fácil.



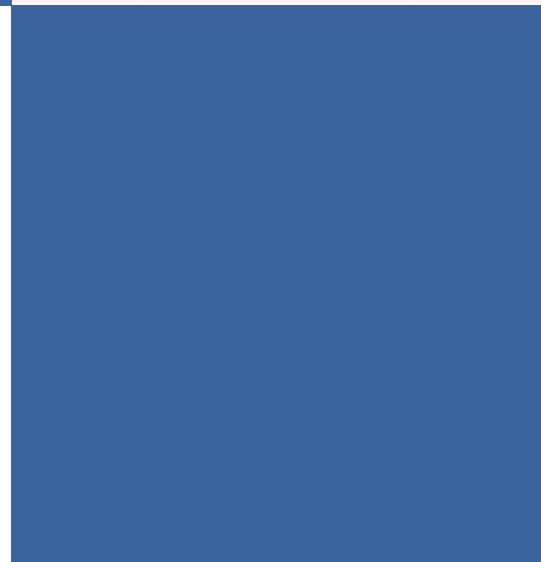

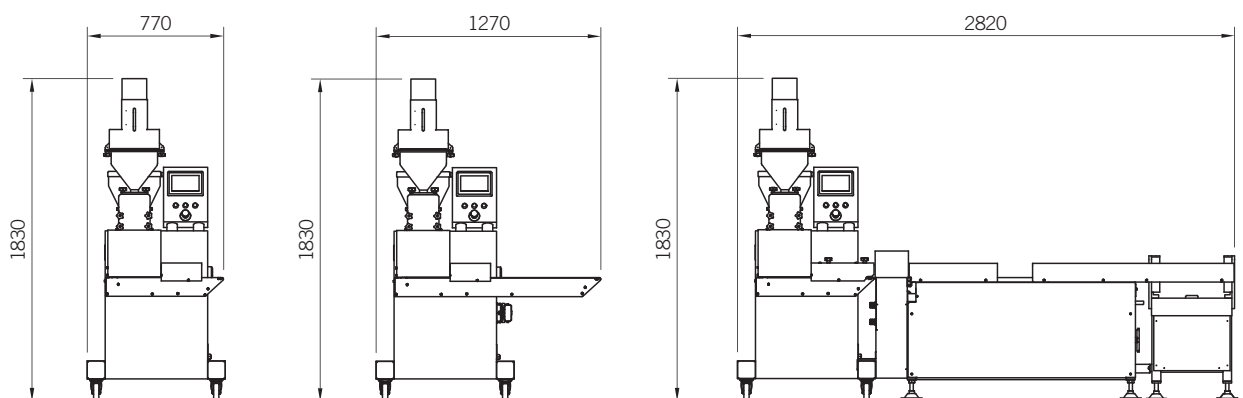

MULTIFORM

MULTIFORM LINE

**DATI TECNICI - TECHNICAL DATA**  
**DONNEES TECHNIQUES - DATOS TÉCNICOS**

	MULTIFORM	MULTIFORM LINE
Capacità tramoggia - Hopper capacity - Capacité trémie - Capacidad tolva	15 lt	15 lt
Capacità tramoggia ripieno - Filling hopper capacity - Capacité trémie farce - Capacidad tolva relleno	7 lt	7 lt
Peso prodotti - Product weight - Poids produits - Peso productos	25/250 g	20/60 g
Produzione massima - Max production - Production maximale - Producción máxima	6000 pz/h	2500 pz/h
Peso - Weight - Poids - Peso	185 kg	370 kg
Potenza - Power - Puissance - Potencia	1.3 kW	2 kW
Consumo aria - Air consumption - Consommation d'air - Consumo de aire	/	2000 NL/h



**MIMAC ITALIA s.r.l.**  
 Via dell'Industria, 22  
 36013 PIOVENE ROCCHETTE  
 Vicenza - Italy  
 Tel. +39 0445 576 250  
 Fax +39 0445 576 112  
 www.mimac.com  
 info@mimac.com

**MIMAC ITALIA S.R.L.**  
 Si riserva il diritto di apportare eventuali modifiche tecniche e costruttive  
 Reserves the right to make any technical and structural modification  
 Se réserve le droit d'apporter éventuelles modifications et de construction  
 Se reserva la facultad de aportar eventuales modificaciones técnicas y constructivas